

Dragon ***Performance Parts***

701-20 INSTRUCTIONS

Tools required:

1. 8mm Socket
2. ½ wrench (13mm will work)
3. Ratchet and extension
4. Flat head screw driver
5. Phillips head screw driver
6. Torque Wrench (ft./lbs.)
7. 5mm Allen wrench
8. Channel lock style pliers
9. Vise

Procedure:

1. Disconnect the negative cable on the battery.
2. Disconnect and remove the air inlet duct from the throttle body.
3. Disconnect the T.P.S. (Throttle Position Sensor) and I.A.C. (Idle Air Control) valve from the wiring harness.
4. Remove the I.A.C. from the Throttle body adapter.
5. Place the base of the I.A.C. in a vise and use the channel lock style pliers, placed near the flange, to rotate the body of the I.A.C. until the harness plug is pointing in the opposite direction from stock, (180 degrees). SEE FIGURE 1
6. Install the I.A.C. onto the new Throttle body using the supplied gasket and two Socket head cap screws with washers. SEE FIGURE 2 FOR ORIENTATION. Be sure to push the I.A.C. towards the throttle body opening (away from the base) before tightening.

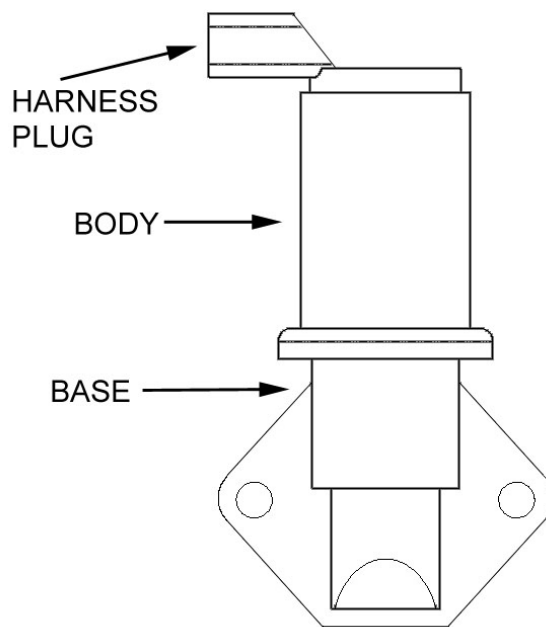

FIGURE 1

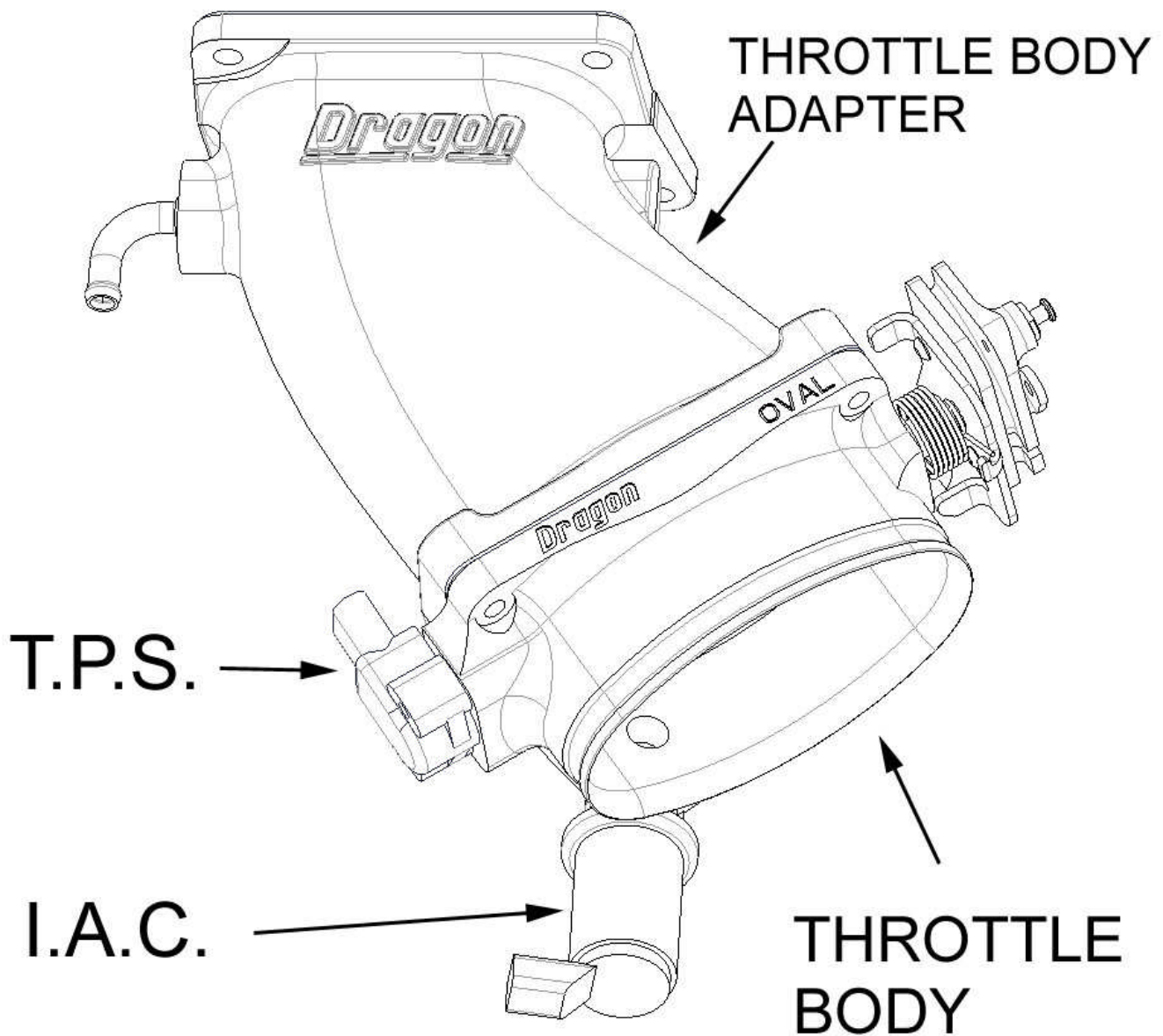

FIGURE 2

7. Disconnect the throttle cable and cruise control cable from the throttle body, by opening the throttle body all the way by hand. Slide the throttle cable and retaining cylinder through the slot on the side of the throttle cam.
8. Remove and keep the four (4) bolts holding the throttle body to the throttle body adapter.
9. Remove the stock T.P.S. from the stock throttle body, if you can't remove the stock T.P.S. screws then grind the heads off of the screws.
10. Install the stock T.P.S. on the new Throttle body, using the supplied screws. SEE FIGURE 2 FOR ORIENTATION. Start the screws and then hold the T.P.S. clockwise against screws, then tighten.

11. Install the new throttle body on the throttle body adapter using the provided gasket and the factory fasteners. Torque to 6 ft./lbs.
12. Disconnect the 3/8 hose from the stock throttle body adapter.
13. Remove the stock throttle body adapter from the supercharger, and retain the factory nuts.
14. Install the Dragon throttle body and adapter assembly onto the supercharger using the supplied gasket and the factory fasteners. Check for clearance between the I.A.C. and the coil cover on the valve cover. If there is interference try lifting up on the throttle body adapter before tightening the nuts. If that is not enough you may need to grind some material off of the edge of the I.A.C. or grind a small notch in the cover.
15. Reconnect the 3/8 rubber hose to the new Throttle body adapter.
16. Reconnect the throttle cable and cruise control cable to the throttle body, checking to make sure the throttle body opens all the way when the gas pedal is pushed all the way down.
17. Reconnect the T.P.S. and the I.A.C. to the wiring harness.
18. Reconnect the air inlet duct to the throttle body.
19. Reconnect the battery.
20. Start the engine and check for vacuum leaks.
21. If engine idle is too high, or hangs at a high RPM, disconnect the negative cable from the battery overnight to reset the computer.
22. If the engine idle is too low use a flat head screwdriver to turn in the idle set screw until desired idle is reached. (use this as a last resort)